

MAGAZINO

# Mobile Pick-Roboter

BVL Innovation Pitches | 2. Dezember 2020



# Agenda



Benjamin Sommer  
(Head of Sales & Marketing)

Magazino GmbH  
Landsberger Str. 234  
80687 München

+49 89 215524153

sommer@magazino.eu

- Was ändert sich in der Robotik?
- Vorstellung Magazino
- Mobile Robotik im E-Commerce
- KLT Handling in der Produktion mit Roboter SOTO
- Möglichkeiten zur Zusammenarbeit
- Fragen & Antworten



# Advanced Robotics

Ein Quantensprung im Vergleich zu klassischer Robotik

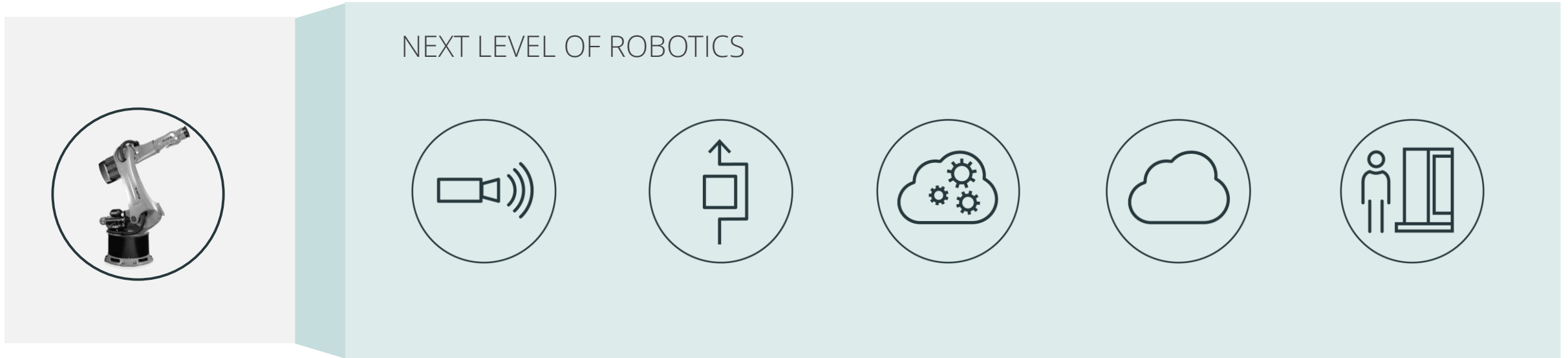

- + Hohe Präzision & Leistung
- Wiederholende, definierte Aufgaben
- Keine Anpassungsfähigkeit an die Umgebung
- Limitierte Wahrnehmungsfähigkeit

deterministisch

Kamera- & Sensorbasiert

Live Entscheidungen & Verhaltensadaption

Lernen mithilfe von künstlicher Intelligenz

Cloud-basiert

Kooperativ

flexibel

intelligent

autonom



# Magazino GmbH

Innovatives Start-Up im Bereich perzeptionsgesteuerte Robotik

## WER IST MAGAZINO?



- Gegründet 2014
- Standort München
- 110+ Mitarbeiter
- 51 mio. Investments von Jungheinrich, Körber Group, Henderson, Zalando & Fiege Logistik etc.

## WAS MACHT MAGAZINO?



Flexible Roboterlösungen für die Intralogistik

Roboter: TORU  
Einsatzbereich: E-Commerce  
Objekte: Schuhkartons

Roboter: SOTO  
Einsatzbereich: Produktion  
Objekte: KLT



# Mobiler Pick-Roboter TORU

Autonomes kommissionieren von Schuhkartons im E-Commerce





MAGAZINO robots at ASICS  
Krefeld, Germany

# SOTO 2

Ein mobiler Roboter für die  
automatisierte KLT-Versorgung





Video SOTO 2



# Entwicklungspartner

Wer begleitet Magazino auf dem Weg zum Go-Live?

## Entwicklungspartner



**VEGA**



**Webasto**

**Miele**



**AGCO**  
Your Agriculture Company



# Unique Selling Point SOTO

SOTO features superior to existing AGV solutions



Storage & Retrieval

up to 1,70 m with existing equipment



High transport capacity

up to 24 Totes one way

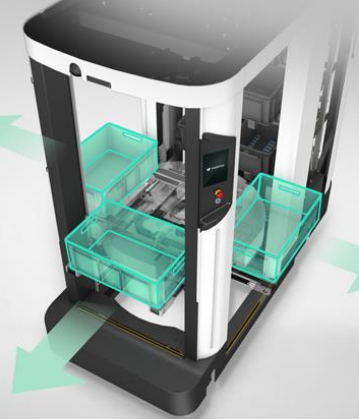

Identification & Grasping from 3 sides

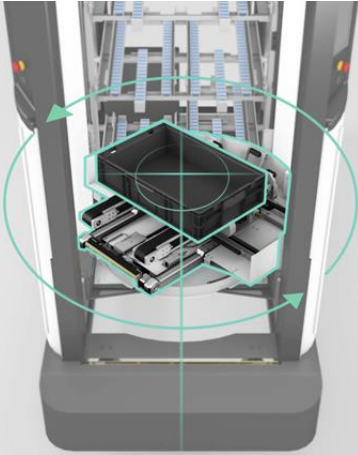

Rotation of the KLT by 270° possible

VS



Limitations for handover systems

Set height + Conveyor belt



Capacity problems

Batch size of 1 Tote



Error rate at handover systems

"blind" incorrect loading (tilt)

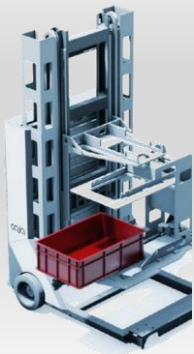

Unflexible supply

Storage and retrieval of totes in one defined position



# Direktversorgung durch SOTO

Vollautomatische Versorgung vom Lager an die Montagelinie

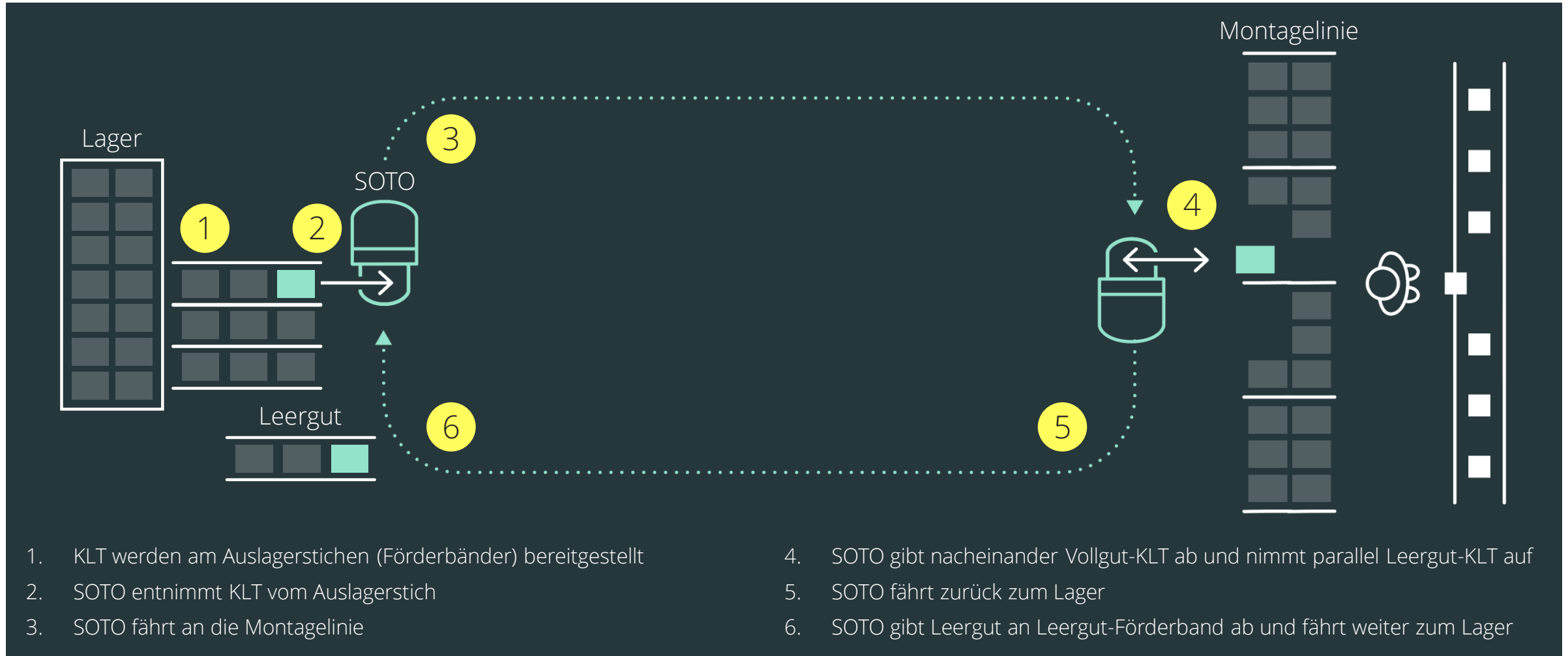

# Magazino SOTO Roadmap

Meilensteine bis zum Roll-Out

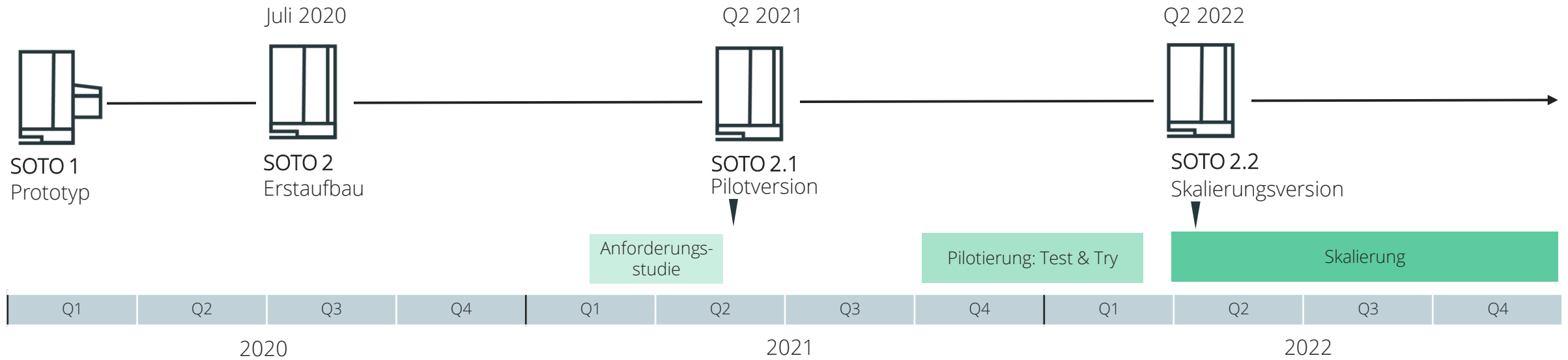

# Zusammenarbeit und Kontakt

Wie können Sie mit Magazino zusammenarbeiten?

## TORU

Use Case: Kommissionierung von  
Schuhen im Warenlager



Sofortige Implementierung möglich  
Noch Projektkapazitäten in 2021

## SOTO

Use Case: Automatische KLT-  
Versorgung in der Produktion



Anforderungsstudie  
ab Q1/2021

Pilotierung  
ab Q3/2021



Benjamin Sommer  
(Head of Sales & Marketing)

Magazino GmbH  
Landsberger Str. 234  
80687 München

+49 89 215524153

sommer@magazino.eu

